

INFORMATION FOR HYGIENIC INSTALLATION

Compact sensors EXspect & EXplore



All brand and product names are registered trademarks of
EXNER PROCESS EQUIPMENT GmbH

Imprint

Issued by:

Exner Process Equipment GmbH

Carl-Metz-Str. 26

D-76275 Ettlingen

Issue date: 2024-10-14

Effective: 2024-07-04

Article number: 9-901-66-004

File: Supplementary sheet EHEDG_3A_EXspect_EXplore_240812

© 2020, Dipl.-Ing. [Graduate Engineer] Detlef Exner

All rights reserved, also for the translation.

The contents of this supplementary sheet may only be reproduced with written approval from EXNER PROCESS EQUIPMENT GMBH, ETTLINGEN.

All technical specifications, drawings, etc. are subject to copyright protection law.

We reserve the right to make technical changes.

Printed on chlorine and acid-free paper consisting of cellulose pulp.

Table of contents

1	Technical data	4
1.1	Specifications.....	4
1.2	Environmental conditions.....	4
1.3	Process conditions.....	4
1.4	Dimensions.....	4
2	Installation in the process	6
2.1	General information.....	6
2.2	Process integration.....	6
2.3	Cleaning notes.....	9
2.4	Servicing notes.....	9

1 Technical data

1.1 Specifications

Components with contact to the process medium	
Material sensor	Stainless steel, 1.4435 (316L)
Surface finish for metal components	Ra <0.37 µm
Measuring window / Optical unit	Sapphire

1.2 Environmental conditions

Ambient temperature: -10...70 °C

Transport and storage temperature: -20...80 °C

1.3 Process conditions

Max. permissible process pressure: 16 bar (EXspect 231 / EXplore 131)

20 bar (EXspect 271 / EXplore 171)

Permissible media temperature: -10...90 °C (EXspect 231 / EXplore 131)

-10...100 °C (EXspect 271 / EXplore 171)

CIP/SIP EXspect 231 / EXplore 131: 135 °C (max. 1 hour)

CIP/SIP EXspect 271 / EXplore 171: 141 °C (max. 2 hours)

1.4 Dimensions

Installation lengths of the EXpect and EXplore sensor series depending on the selected process connection (code "TC" or "VRN"):

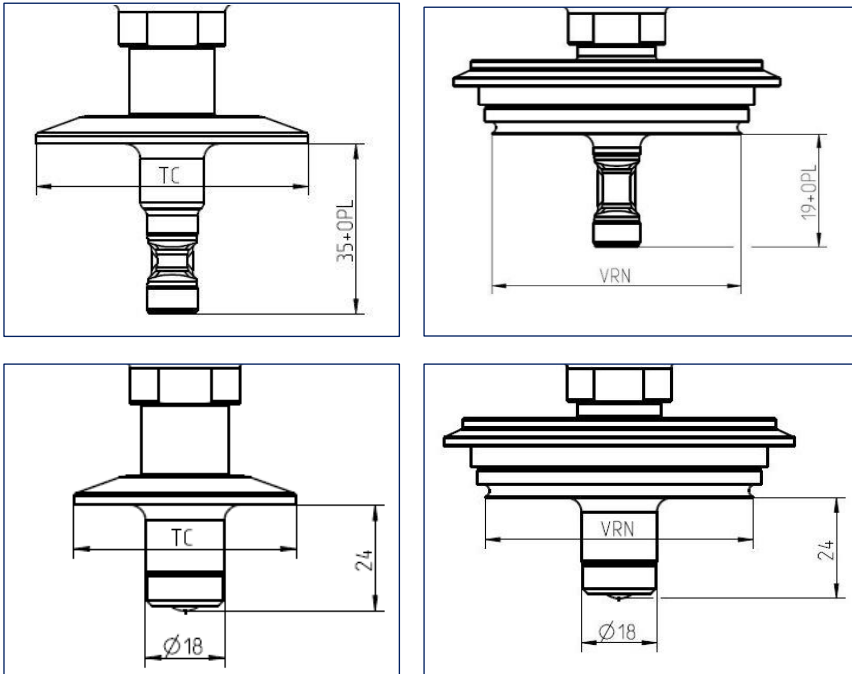

Fig. 1: Installation length in pipe (Note: OPL = optical path length)

2 Installation in the process

2.1 General information

When installing the sensor in the process, ensure that no areas which are difficult to clean (dead spaces) arise. The sensor must always be installed in a self-emptying position. In particular when using Tri-Clamp process connections, the respective current EHEDG and other current regulations regarding the installation position must be observed. The EHEDG position paper under www.ehedg.org provides information about this.

For sealing between the sensor and process connection, exclusively seals may be used here which are approved for use in the food area. The current version of the EHEDG position paper always applies here too.

The EXspect and EXplore series sensors can be cleaned using "Cleaning-In-Place" (CIP) and sterilised using "Sterilisation-In-Place" (SIP). Here, the maximum permissible temperatures and times in Section 1.3 must be observed.

2.2 Process integration

Sensor installation

The following must be observed:

- Easy access to the sensor for maintenance and inspection must be taken into account when selecting its assembly position.
- The sensor must be assembled to enable self-emptying of this area. Horizontal surfaces and fluid accumulation must be avoided.
- The arrangement at tanks must be selected in a way that the cleaning of the sensor and process connection can be guaranteed at all times.

Dimensions for the installation with Tri-Clamp

The following rule must be met for installation in the process: $L < (D-d)$

Ød: EXspect 231 / EXplore 131 = 15 mm

Ød: EXspect 271 / EXplore 171 = 18 mm

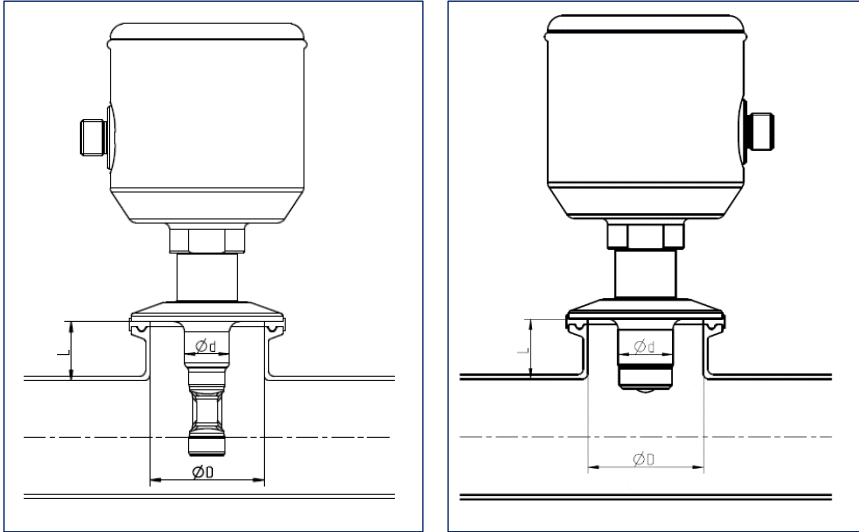

Fig. 2: Process integration (on example of the EXspect series)

Installation positions

The following graph shows the favoured installation locations for the sensor.

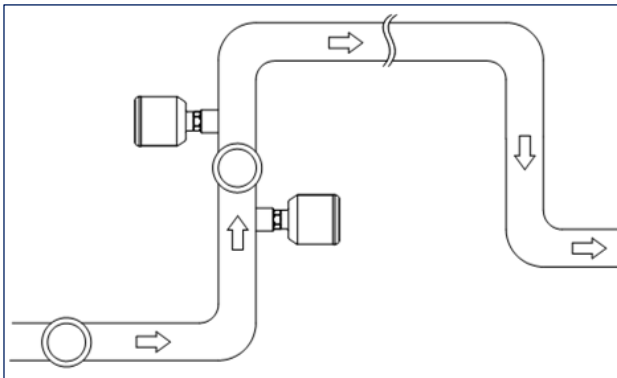

Fig. 3: Installation positions (schematic diagram)

NOTE

It must be ensured that the pipe is always filled completely. Air or air bubbles cause disturbances which may falsify the measurement values. Installation of the sensor in the riser pipe is therefore preferential.

When installing the EXspect 231 and EXplore 131 sensors, it must be observed that the opening with the measuring windows is in the flow direction of the medium.

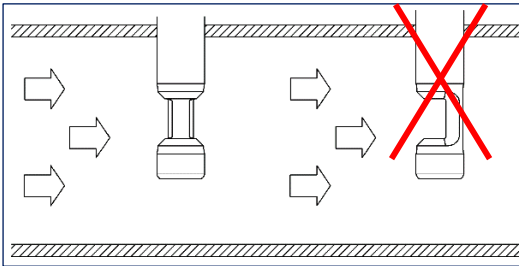

Fig. 4: Positioning the EXspect 231 / EXplore 131 sensors

For easy orientation, corresponding markings are provided on the process connections as alignment aids.

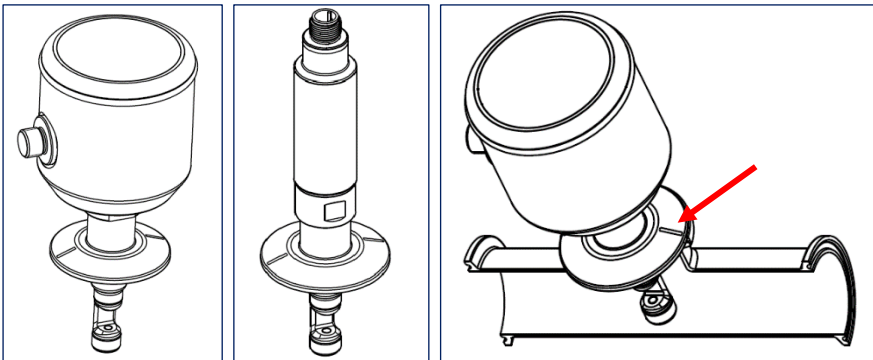

Fig. 5: Markings on the EXspect 231 / EXplore 131 process connections

2.3 Cleaning notes

The EXspect and EXplore sensors are suitable for applications which are cleaned/sterilised using the typical CIP/SIP methods.

Depending on the cleaning process, different acid and alkali concentrations are applied, typically with a concentration between 0 and 1.5%. This also takes place in connection with corresponding cleaning temperatures which are recommended by the manufacturer of the cleaning agents. Concentrations and temperatures vary dependent on the plants or plant components to be cleaned and the overall process to be cleaned.

2.4 Servicing notes

Regular inspections are essential for guaranteeing process safety. These include, above all, the inspection or replacement of the process seals used. In case of leakage, they must be replaced without delay in order to avoid contamination of the process medium. Even if there are no damages, we recommend replacing the respective seal at least annually.

NOTE

Observe additionally the safety and maintenance information provided in the operating instructions for the respective product.

Replacement of seals

The following must be observed:

- The seals used must meet the requirements stipulated in the EHEDG position paper (e.g. T-ring seal from *Combifit International B.V.* for clamp connection).
- For safe seal removal, release the respective sensor from the process connection. Then, remove the seal cautiously from the groove without using metallic tools which could damage the sealing surface.
- Clean the sealing surface and all adjacent areas with a soft brush and a mild cleaning agent. Then, rinse with clear water.

- Check the sealing surface for possible damages. A sealing surface which is not intact may result in leakage and contamination. Sensors with damaged sealing surfaces must be replaced accordingly.
- Insert the new seal into the designated groove without using tools. If the seal is damaged during this procedure, it must be replaced without delay.
- Assemble the sensor in correct position on the respective process connection. Pay attention to the correct torque for tightening the retaining clips.
- We recommend cleaning/sterilisation (CIP/SIP) after installation.



Exner Process Equip-
ment GmbH
Carl-Metz-Str. 26
D-76275 Ettlingen
Germany

tel +49 (0)7243-94
54 29-0
fax +49 (0)7243-94
54 29-99
mail info@e-p-e.de

www.e-p-e.com